

**IMPORTANT: FAILURE TO INSTALL AND FINISH THIS PRODUCT IN ACCORDANCE WITH APPLICABLE BUILDING CODES AND JAMES HARDIE WRITTEN APPLICATION INSTRUCTIONS MAY LEAD TO PERSONAL INJURY, AFFECT SYSTEM PERFORMANCE, VIOLATE LOCAL BUILDING CODES, AND VOID THE PRODUCT ONLY WARRANTY. BEFORE INSTALLATION, CONFIRM THAT YOU ARE USING THE CORRECT HARDIE ZONE INSTRUCTIONS. TO DETERMINE WHICH HARDIE ZONE APPLIES TO YOUR LOCATION, VISIT [WWW.HARDIEZONE.COM](http://WWW.HARDIEZONE.COM) OR CALL 1-866-942-7343 (866 9HARDIE)**

## STORAGE & HANDLING:

Store flat and keep dry and covered prior to installation. Installing siding wet or saturated may result in shrinkage at butt joints. Carry planks on edge. Protect edges and corners from breakage. James Hardie is not responsible for damage caused by improper storage and handling of the product.

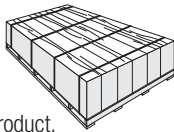

## CUTTING INSTRUCTIONS

### OUTDOORS

1. Position cutting station so that wind will blow dust away from user and others in working area.
2. Use one of the following methods:
  - a. Best:
    - i. Score and snap
    - ii. Shears (manual, electric or pneumatic)
  - b. Better:
    - i. Dust reducing circular saw equipped with a HardieBlade® saw blade and HEPA vacuum extraction
  - c. Good:
    - i. Dust reducing circular saw with a HardieBlade saw blade (only use for low to moderate cutting)

### INDOORS

1. Cut only using score and snap, or shears (manual, electric or pneumatic).
  2. Position cutting station in well-ventilated area
- NEVER use a power saw indoors
  - NEVER use a circular saw blade that does not carry the HardieBlade saw blade trademark
  - NEVER dry sweep – Use wet suppression or HEPA Vacuum

Important Note: For maximum protection (lowest respirable dust production), James Hardie recommends always using "Best"-level cutting methods where feasible.

NIOSH-approved respirators can be used in conjunction with above cutting practices to further reduce dust exposures. Additional exposure information is available at [www.jameshardie.com](http://www.jameshardie.com) to help you determine the most appropriate cutting method for your job requirements. If concern still exists about exposure levels or you do not comply with the above practices, you should always consult a qualified industrial hygienist or contact James Hardie for further information.

SD083105

## GENERAL REQUIREMENTS:

- References to the 2005 National Building Code (NBC) of Canada are made throughout this document. Local building code requirements may supersede the NBC in some locations.
- HardieShingle panels can be installed over braced wood or steel studs spaced a maximum of 610mm (24") o.c. or directly to minimum 11.1mm (7/16") thick sheathing. HardieShingle Individual Shingles must be installed directly to minimum 11.1mm (7/16") thick sheathing.
- HardieShingle panels can also be installed over foam insulation/sheathing up to 25mm (1") thick. When using foam insulation/sheathing, avoid over-driving nails (fasteners), which can result in dimpling of the siding due to the compressible nature of the foam insulation/sheathing. Extra caution is necessary if power-driven nails (fasteners) are used for attaching siding over foam insulation/sheathing.
- A water-resistive barrier is required in accordance with Part 9.27.3.2 of the NBC. The water-resistive barrier must be appropriately installed with penetration and junction flashing in accordance with Part 9.27.3 of the NBC. James Hardie will assume no responsibility for water infiltration.
- When installing James Hardie products all clearance details in figs. 1, 2, 3, 4, 5, 6 & 7 must be followed.
- Adjacent finished grade must slope away from the building in accordance with local building codes - typically a minimum of 152 mm (6") in the first 3m (10').
- Do not install James Hardie products, such that they may remain in contact with standing water.
- HardieShingle lap siding may be installed on vertical wall applications only.
- DO NOT use stain on James Hardie® products.

## CLEARANCES

Install siding and trim products in compliance of Part 9.27.2.4 of the NBC which requires a minimum 200mm (8") for clearance between the bottom edge of the siding and the adjacent finished grade.

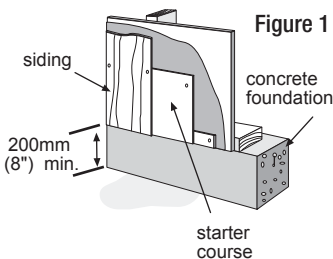

Maintain a minimum 50mm (2") clearance between James Hardie® products and paths, steps and driveways.

Figure 2

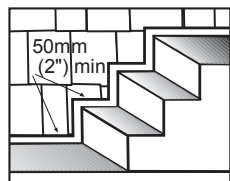

Maintain a minimum 50mm (2") clearance between James Hardie products and decking material.

Figure 3

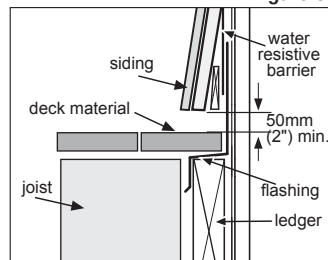

At the juncture of the roof and vertical surfaces, flashing and counterflashing shall be installed per the roofing manufacturer's instructions. Part 9.27.2.4 requires a minimum 50mm (2") clearance between the roofing and the bottom edge of the siding and trim.

Figure 4

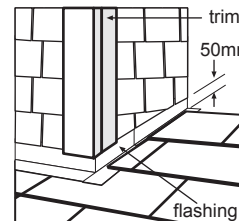

## WARNING: AVOID BREATHING SILICA DUST

James Hardie® products contain respirable crystalline silica, which is known to the State of California to cause cancer and is considered by IARC and NIOSH to be a cause of cancer from some occupational sources. Breathing excessive amounts of respirable silica dust can also cause a disabling and potentially fatal lung disease called silicosis, and has been linked with other diseases. Some studies suggest smoking may increase these risks. During installation or handling: (1) work in outdoor areas with ample ventilation; (2) use fiber cement shears for cutting or, where not feasible, use a HardieBlade® saw blade and dust-reducing circular saw attached to a HEPA vacuum; (3) warn others in the immediate area; (4) wear a properly-fitted, NIOSH-approved dust mask or respirator (e.g. N-95) in accordance with applicable government regulations and manufacturer instructions to further limit respirable silica exposures. During clean-up, use HEPA vacuums or wet cleanup methods - never dry sweep. For further information, refer to our installation instructions and Material Safety Data Sheet available at [www.jameshardie.com](http://www.jameshardie.com) or by calling 1-800-9HARDIE (1-800-942-7343). FAILURE TO ADHERE TO OUR WARNINGS, MSDS, AND INSTALLATION INSTRUCTIONS MAY LEAD TO SERIOUS PERSONAL INJURY OR DEATH.

SD090905

Maintain a 6mm (1/4") clearance between the bottom of James Hardie® products and horizontal flashing. Do not caulk gap.

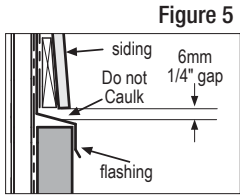

Maintain a minimum 25mm (1") gap between gutter end caps and siding & trim.

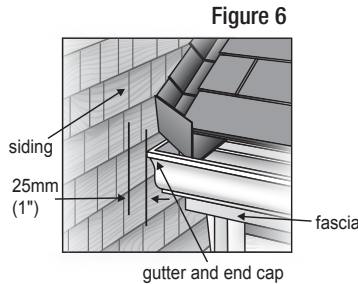
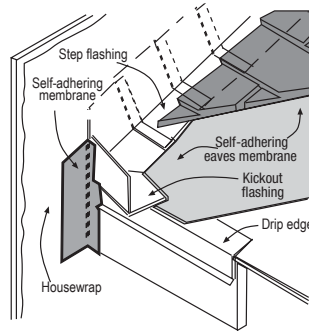

Figure 7



### KICKOUT FLASHING

Because of the volume of water that can pour down a sloped roof, one of the most critical flashing details occurs where a roof intersects a sidewall. The roof must be flashed with step flashing. Where the roof terminates, install a kickout to deflect water away from the siding.

It is best to install a self-adhering membrane on the wall before the subfascia and trim boards are nailed in place, and then come back to install the kickout.

**Figure 7, Kickout Flashing** † To prevent water from dumping behind the siding and the end of the roof intersection, install a "kickout" of sufficient length and angle to direct the water running down the roof away from the siding.

## STAGGERED EDGE NOTCHED PANELS

### INSTALLATION

#### Fastener Requirements

2.1mm x 4.7mm HD x 38mm (1.5") long ringshank nails are used for fastening HardieShingle® Staggered Edge Notched Panels to both framing and to 11.1mm (7/16") thick APA rated sheathing.

#### HardieShingle® Staggered Edge Notched Panel Installation

Install HardieShingle® notched panels with joints butted in moderate contact. Due to overlapping of the joints, caulk is not required except where panels abut trim boards. (fig. 8 & 10). Ensure keyways do not line up on subsequent courses.

- 1) Install a 32mm (1 1/4") starter strip, and a 8 1/4" HardiePlank® lap siding starter course.
- 2) Trim the first panel from the end abutting trim (the left side in figures 8 & 10) to hit the furthest stud. When installing over a band board, trim the bottom of the panel to create a straight edge, leave 6mm (1/4") gap between bottom of siding and flashing (fig. 9).
- 3) Secure panel, leaving 3mm (1/8") gap for caulk at trim and continue the course along the wall.
- 4) Start the second course, by removing the equivalent of one full stud cavity, again from the end abutting the trim. This is to prevent pattern repetition. Repeat step 3.
- 5) Start the third course, by removing the equivalent of two full stud cavities and repeat step 3.
- 6) Continue up the wall repeating steps 2 through 6 until desired height is reached.

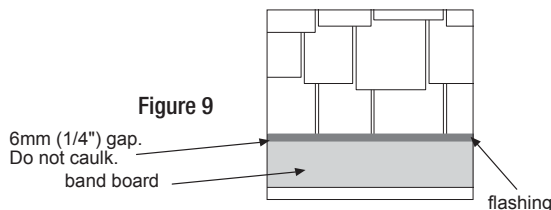

Steps 1-4

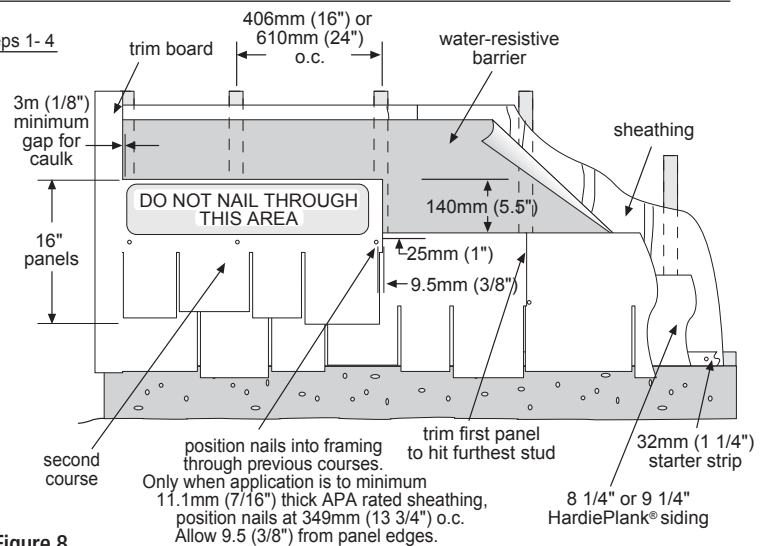
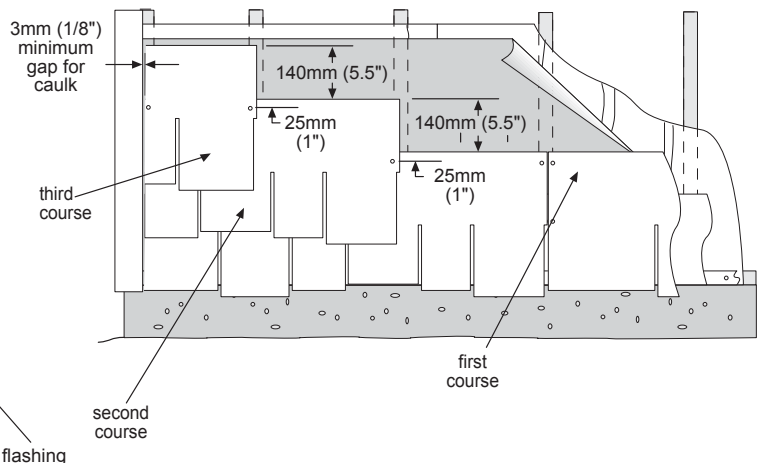

Figure 8

Steps 5 & 6



## HARDIESHINGLE STAGGERED EDGE NOTCHED PANEL COVERAGE

Panels for sidewall applications are available in 48" lengths. Pieces needed for one square (9.3 sq.m./100 sq.ft.) of product coverage = approximately 55, based on a maximum 140mm (5.5") exposure from the top edge of HardieShingle panels in subsequent courses (refer to Figure 8).

## STRAIGHT EDGE NOTCHED PANELS INSTALLATION

Maximum Exposure of 178mm (7")

Figure 10

### REFER TO STAGGERED EDGE INSTRUCTIONS ABOVE

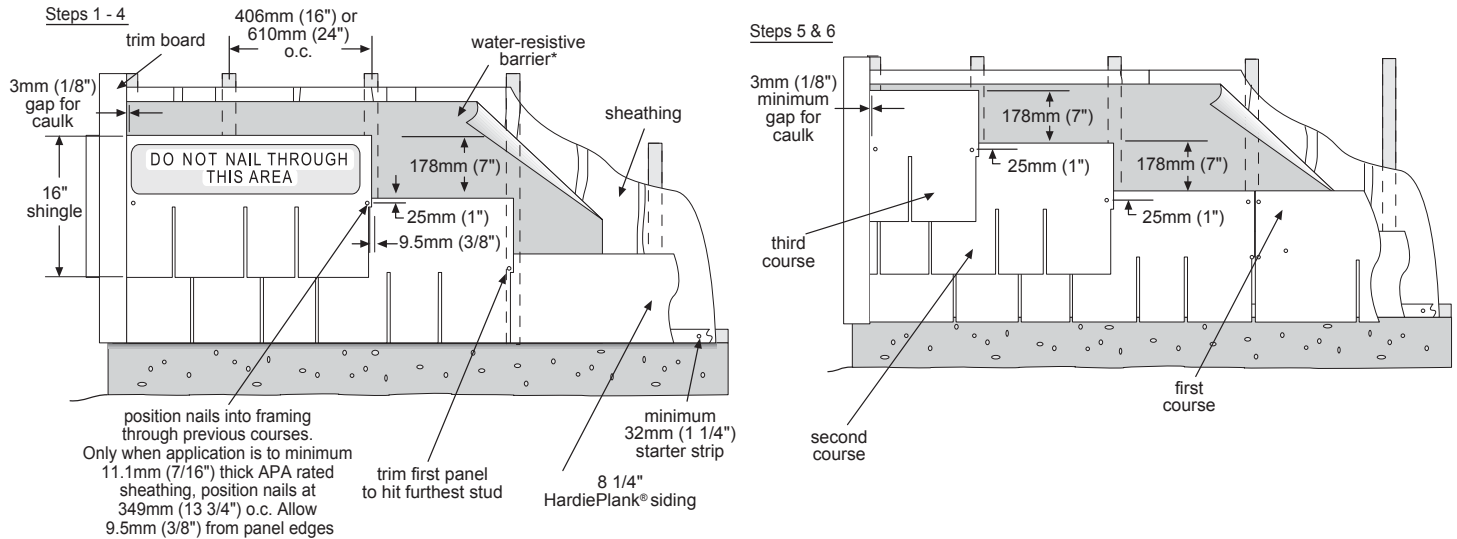

## HARDIESHINGLE® STRAIGHT EDGE NOTCHED PANEL COVERAGE

Panels for sidewall applications are available in 1.2m (48") lengths. Pieces needed for one square (9.3 sq.m./100 sq.ft.) of product coverage = approximately 45, based on maximum 178mm (7") exposure.

## INDIVIDUAL SHINGLE

### INSTALLATION

#### Fastener Requirements

2.3mm x 5.6mm HD x 38mm or 3mm x 9.4 HD x 32mm long corrosion resistant siding nails are used for fixing HardieShingle® siding to 11.1mm thick APA rated OSB.

#### HardieShingle Individual Shingle Installation

Due to overlapping of the joints, caulk is not required except where panels abut trim boards. Space shingles a maximum 6mm apart and leave a minimum lap of 38mm between successive courses (figure 12).

- 1) Install 32mm starter strip and a 8 1/4" or 9 1/4" wide HardiePlank® siding starter course.
- 2) Install first shingle from the end abutting trim (figure 11).
- 3) Secure shingle, leaving a 3mm gap for caulk at trim and continue the course along the wall.
- 4) Start the second course, leaving a minimum lap of 38mm between successive courses, again from the end abutting the trim. Repeat step 3.
- 5) Continue up the wall repeating steps 2 through 5 until desired height is reached.

Figure 11

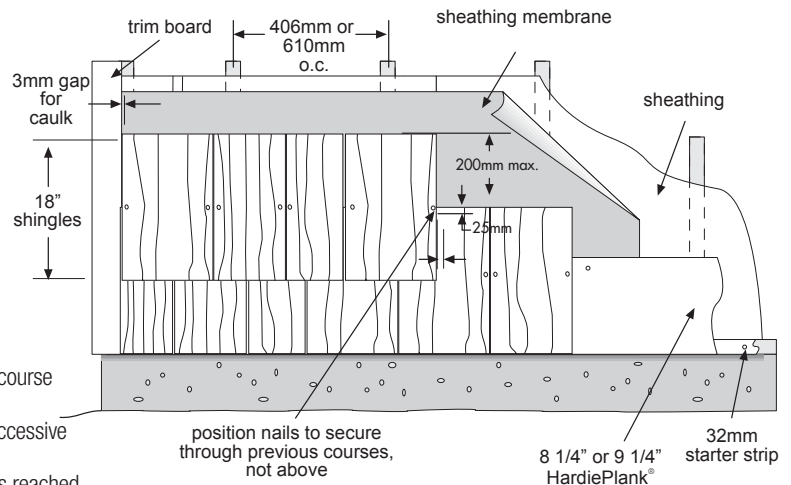

## HARDIESHINGLE INDIVIDUAL SHINGLE COVERAGE

Shingles for sidewall applications are available in 6", 8" and 12" widths. Bundles needed for one square (9.3 sq. m./100 sq. ft.) of product coverage:

Shingle Width	Number of Bundles	Pieces per Bundle
6"	6	11
8"	6	11
12"	6	11

Figure 12

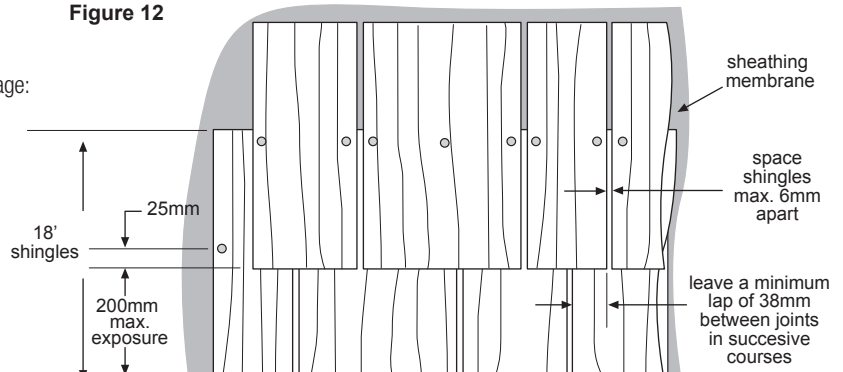

## GABLE INSTALLATION:

Installation over sheathing is recommended for gables.

- 1) Install a 32mm (1 1/4") starter strip and a 8-1/4" wide HardiePlank® lap siding starter course.
- 2) Begin Panel installation by first marking a plumb line down the center of the gable. Center either a keyway or a half-round along this line to ensure a symmetric finished appearance (fig. 13 & 14).
- 3) Start second course, by removing the equivalent of one full stud cavity and ensuring the seam is located over the midpoint of the lower course.
- 4) Cut the edge of the panels to correspond with the rake angle of the gable leaving a 1/8" gap for caulk at the trim.
- 5) If the rake angle cuts through a keyway of a complete panel or significantly weakens the end of the panel, use face nails to secure the end pieces as shown (fig. 15)
- 6) Continue installation aligning courses as indicated. At the top of the gable, face nails will be required for the final pieces (fig. 16)

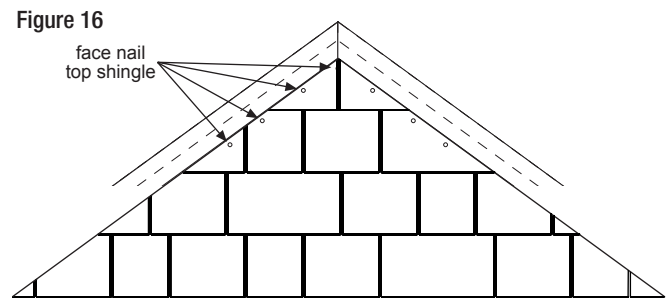
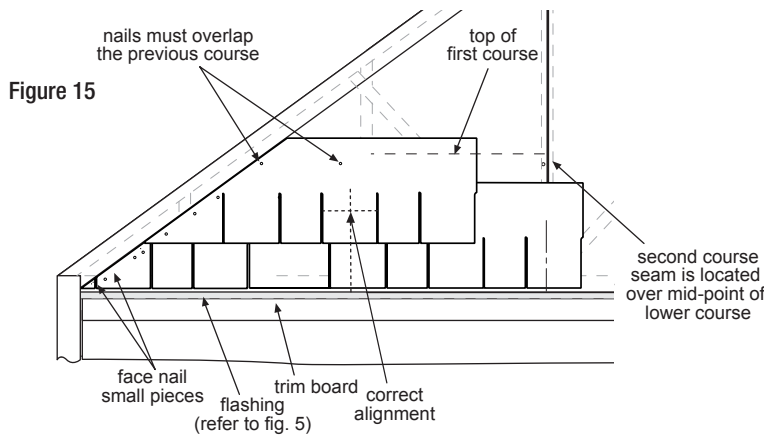
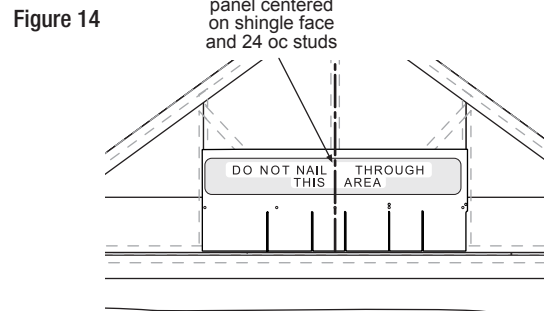
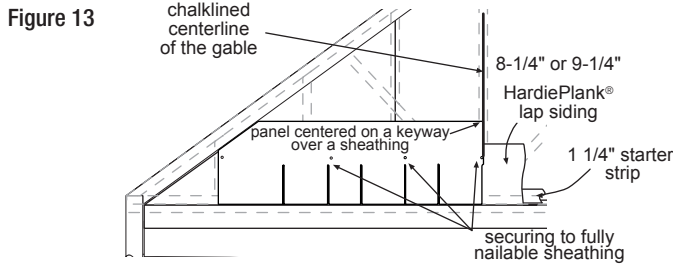

## CORNER DETAILS

- A. Panels butted against corner boards.
- B. Panels butted against square wood strip on inside corner, flashing behind.
- C. Laced outside corner.
- D. Laced inside corner.

minimum 25mm (1") thick trim

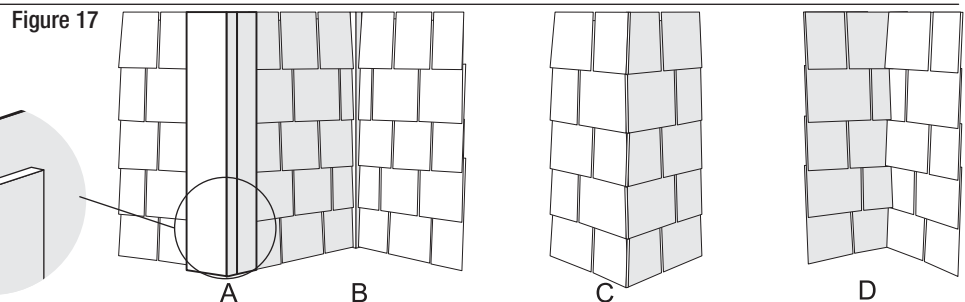
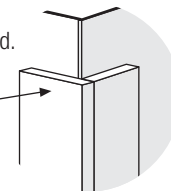

## WINDOWS AND DOORS

Building wall components such as windows, doors and other exterior wall penetrations shall be installed in accordance with the component manufacturer's written installation instructions and local building codes. Where windows or doors are installed, continue the application of siding as if the wall is complete. Trimming for the opening and using the resulting piece may throw off the spacing above the break.

## GENERAL FASTENING REQUIREMENTS

Fasteners must be corrosion resistant, galvanized, or stainless steel. Electro-galvanized are acceptable but may exhibit premature corrosion. James Hardie recommends the use of quality, hot-dipped galvanized nails. James Hardie is not responsible for the corrosion resistance of fasteners. Stainless steel fasteners are recommended when installing James Hardie® products near the ocean, large bodies of water, or in very humid climates.

- Consult applicable code compliance report for correct fasteners type and placement to achieve specified design wind loads.
- NOTE: Published wind loads may not be applicable to all areas where Local Building Codes have specific jurisdiction. Consult James Hardie Technical Services if you are unsure of applicable compliance documentation.
- Drive fasteners perpendicular to siding and framing.
- Fastener heads should fit snug against siding (no air space). (fig. A)
- Do not over-drive nail heads or drive nails at an angle.
- If nail is countersunk, caulk nail hole and add a nail. (fig. B)
- For wood framing, under driven nails should be hit flush to the plank with a hammer (For steel framing, remove and replace nail).
- Do not use aluminum fasteners, staples, or clipped head nails.

## PNEUMATIC FASTENING

James Hardie products can be hand nailed or fastened with a pneumatic tool. Pneumatic fastening is highly recommended. Set air pressure so that the fastener is driven snug with the surface of the siding. A flush mount attachment on the pneumatic tool is recommended. This will help control the depth the nail is driven. If setting the nail depth proves difficult, choose a setting that under drives the nail. (Drive under driven nails snug with a smooth faced hammer - Does not apply for installation to steel framing).



Figure A



Figure B



do not under drive nails



DO NOT STAPLE

## CUT EDGE TREATMENT CAULKING

All field cut edges must be painted or primed.

Elastomeric Joint Sealant is required in accordance with Part 9.27.4 of the NBC, complying with ASTM C920 Grade NS, Class 25 or higher or a Latex Joint Sealant complying with ASTM C834.  
Caulking/Sealant must be applied in accordance with the caulking/sealant manufacturer's written instructions or ASTM C1193.

## PRIMING & PAINTING

DO NOT use stain on James Hardie® products. James Hardie products must be painted within 180 days for primed product and 90 days for unprimed. In addition non ColorPlus® product versions of HardieShingle® Siding require a field applied prime coat. 100% acrylic primers and topcoats are recommended. Do not paint when wet. For application rates refer to paint manufacturers specifications. Back rolling is recommended when paint is spray applied.

## COLORPLUS® TECHNOLOGY CAULKING, TOUCH-UP & LAMINATE

- Touch up nicks, scrapes and nail heads using the ColorPlus® Technology touch up applicator. Touch-up paint should be used sparingly. If large areas require touch-up, replace the damaged area with new HardieShingle® siding with ColorPlus® Technology.
- Laminate sheet must be removed immediately after installation of each course.
- Terminate non-factory cut edges into trim where possible, and caulk. Color matched caulks are available from your ColorPlus® product dealer.
- Treat all other non-factory cut edges using the ColorPlus Technology edge coaters, available from your ColorPlus product dealer.

## PAINTING JAMES HARDIE® SIDING AND TRIM PRODUCTS WITH COLORPLUS® TECHNOLOGY

When repainting ColorPlus products, James Hardie recommends the following regarding surface preparation and topcoat application:

- Ensure the surface is clean, dry, and free of any dust, dirt, or mildew
- Repriming is normally not necessary
- 100% acrylic topcoats are recommended
- DO NOT use stain or oil/alkyd base paints on James Hardie® products
- Apply finish coat in accordance with paint manufacturers written instructions regarding coverage, application methods, and application temperature

### COMPLIANCE:

HardieShingle® siding complies with ASTM Specification C1186 (Grade II, Type A) and ISO Standard 8336 (Category 3, Type A).

When tested in accordance with CAN/ULC-S102, the product is recognized to have the following properties:  
Flame Spread Rating: 0,  
Smoke Developed Classification: 0.

When tested in accordance with CAN/ULC-S114, the product is recognized as noncombustible.

### RECOGNITION:

HardieShingle® siding may be recognized as an alternative to exterior wall cladding in section 9.27 of the NBC. For technical assistance, call 1-800-9-HARDIE.

## WIND LOAD TABLE

### STRAIGHT EDGE NOTCHED PANELS

Table 1 - Straight Edge Notched Panel applied to a minimum 11.1 mm (7/16") thick OSB sheathing or equivalent sheathing only.

Fastener Type	Fastener Spacing	Frame Type	Frame Spacing	Ultimate Load @ Failure	
Min. 2.1 mm shank x 4.7 mm HD x 38 mm (1 1/2") long corrosion resistant siding nail	350 mm (13") o.c. to notched panels installed with butt edges in alignment	Min. 11.1 mm (7/16") thick APA rated OSB sheathing or equivalent	NA	3.25 kPa	68 psf
Min. 2.1 mm shank x 4.7 mm HD x 38 mm (1 1/2") long corrosion resistant siding nail	350 mm (13") o.c. to notched panels installed with butt edges in staggered	Min. 11.1 mm (7/16") thick APA rated OSB sheathing or equivalent	NA	2.92 kPa	61 psf

Table 2 - Straight Edge Notched Panel applied to braced wood or metal framing.

Min. 2.1 mm shank x 4.7 mm HD x 38 mm (1 1/2") long corrosion resistant siding nail or equivalent screw	Each framing member	Nominal 2x4 wood s.g.= 0.40 or Min. No. 20 ga. x 92 mm x 35 mm C-stud or equivalent	406mm (16")	9.19 kPa	192 psf
Min. 2.1 mm shank x 4.7 mm HD x 38 mm (1 1/2") long corrosion resistant siding nail	Each framing member	Nominal 2x4 wood s.g.= 0.40 or Min. No. 20 ga. x 92 mm x 35 mm C-stud or equivalent	610mm (24")	4.64 kPa	97 psf

## WIND LOAD TABLE

### STAGGERED EDGE NOTCHED PANELS

Table 1 - Staggered Edge Notched Panel applied to a minimum 11.1 mm thick OSB sheathing or equivalent.

Fastener Type	Fastener Spacing	Frame Type	Frame Spacing	Ultimate Load @ Failure	
Min. 2.1 mm shank x 4.7 mm HD x 38 mm (1 1/2") long corrosion resistant siding nail	350 mm (13") o.c. to notched panels installed with butt edges in alignment	Min. 11.1 mm (7/16") thick APA rated OSB sheathing or equivalent	NA	3.2 kPa	67 psf
Min. 2.1 mm shank x 4.7 mm HD x 38 mm (1 1/2") long corrosion resistant siding nail	350 mm (13") o.c. to notched panels installed with butt edges in alignment	Min. 11.1 mm (7/16") thick APA rated OSB sheathing or equivalent	NA	2.9 kPa	61 psf

Table 2 - Staggered Edge Notched Panel applied to braced wood.

Min. 2.1 mm shank x 4.7 mm HD x 38 mm (1 1/2") long corrosion resistant siding nail	Each framing member	Nominal 2x4 wood s.g.= 0.40	406mm (16")	9.1 kPa	190 psf
Min. 2.1 mm shank x 4.7 mm HD x 38 mm (1 1/2") long corrosion resistant siding nail	Each framing member	Nominal 2x4 wood s.g.= 0.40	610mm (24")	4.6 kPa	96 psf

### METRIC TO IMPERIAL CONVERSION TABLE

The following table provides a conversion of the nominal metric measurements presented in these installation instructions to nominal Imperial fraction measurement values.

<b>mm</b>	<b>inches</b>	<b>mm</b>	<b>inches</b>	<b>mm</b>	<b>inches</b>	<b>mm</b>	<b>inches</b>
2.3	3/32	7.5	5/16	32	1-1/4	200	8
2.4	3/32	8.2	21/64	35	1-3/8	210	8-1/4
2.9	1/8	9	23/64	38	1-1/2	241	9-1/2
3	1/8	9.5	3/8	41	1-5/8	305	12
5.6	7/32	11.1	7/16	50	2	350	13
5.7	7/32	12	15/32	91	3-5/8	406	16
6	15/64	19	3/4	150	6	610	24
6.7	17/64	25	1	190	7-1/2		

RECOGNITION: In accordance with ICC-ES Legacy Report NER-405, HardieShingle® Staggered Edge Notched Panels are recognized as a suitable alternate to that specified in: the BOCA National Building Code/1999, the 1997 Standard Building Code, the 1997 Uniform Building Code, the 1998 International One- and Two-Family Dwelling Code, the 2003 International Building Code, and the 2003 International Residential Code for One-and Two-Family Dwellings. HardieShingle Staggered Edge Notched Panels are also recognized for application in the following: City of Los Angeles Research Report No. 24862, State of Florida listing FL#889, .02, U.S. Dept. of HUD Materials Release 1263c, Texas Department of Insurance Product Evaluation EC-23, City of New York MEA 223-93-M, and California DSA PA-019. These documents should also be consulted for additional information concerning the suitability of this product for specific applications.